

# Control electronics of the robot Ragno

Written by Krzysztof

Wednesday, 02 February 2011 17:21 - Last Updated Wednesday, 02 February 2011 17:29

---

The robot's sensors and its short characteristics are shown below:

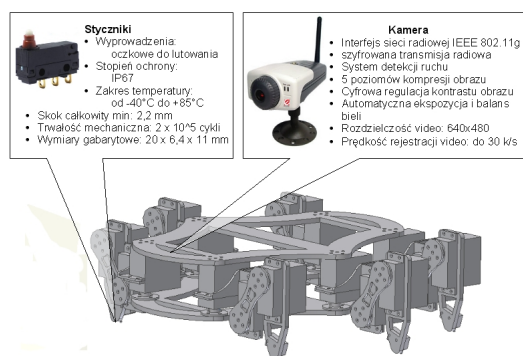
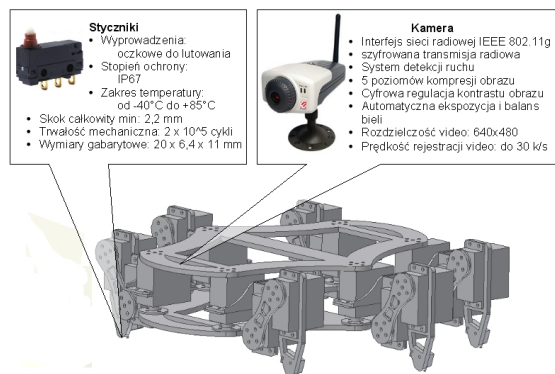

## Akcelerometr ADXL322

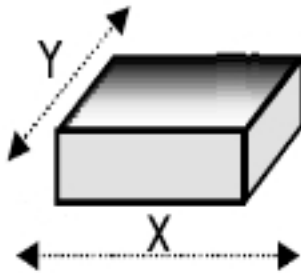

- Wymiary 4x4mm
- Zakres  $\pm 2g$
- Wyjście analogowe
- Niski pobór prądu
- Lekki
- Mała zawartość szumów

## RATE AXIS

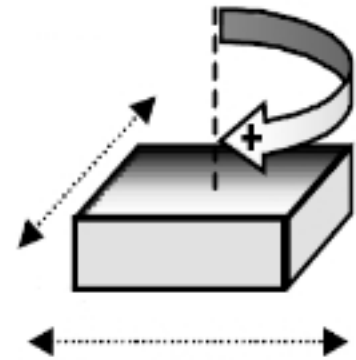

## Żyrosk

- Wy
- Za
- Wy
- Wy
- ter
- lek

